

S1-..

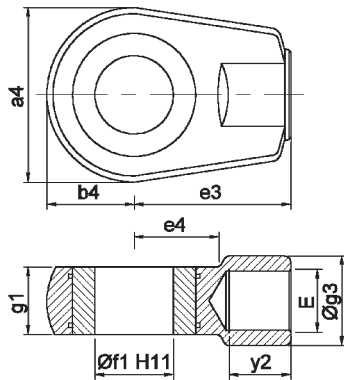

G2-..

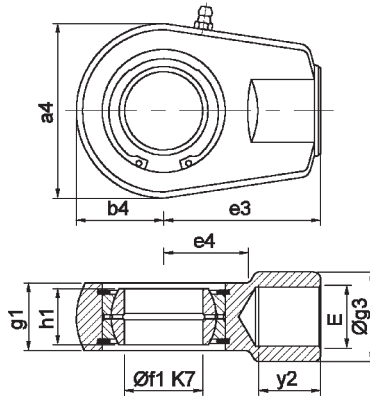

G2-..B

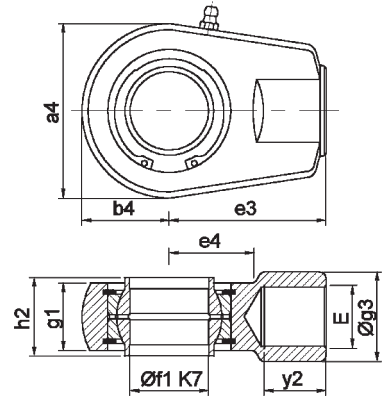

G6-..

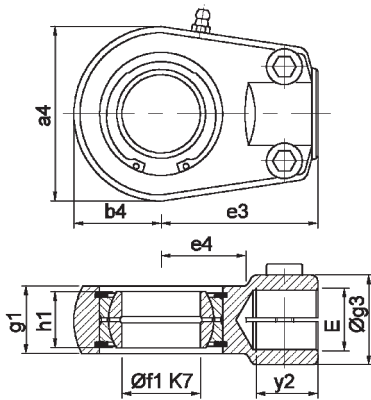

G6-..B

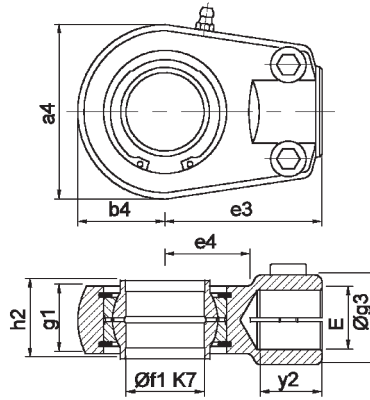

G1-..

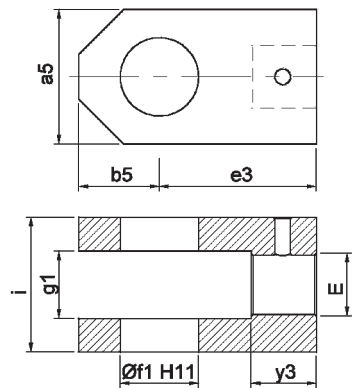

TYPE	Dimensions (mm)																				
	Cyl. bore	E	a4	a5	b4	b5	e3	e4	f1	g1	g3	h1	h2	i	y2	y3					
	G1-15																				
S1	G1-20	G2- 20	G2-20B	G6- 20	G6-20B	40	M14 x 1,5		30		15	47		15	15		12			27	
S1	G1-25	G2- 25	G2-25B	G6- 25	G6-25B	50	M16 x 1,5	56	40	28	20	50	25	20	19	25	16	24	39	17	23
S1	G1-30	G2- 30	G2-30B	G6- 30	G6-30B	60/63/65/70	M22 x 1,5	64	55	32	30	60	30	30	28	32	22	30	56	23	25
S1	G1-35	G2- 35	G2-35B	G6- 35	G6-35B	80/90	M28 x 1,5	78	60	39	36	70	38	35	30	40	25	35	62	29	29
S1	G1-40	G2- 40	G2-40B	G6- 40	G6-40B	100/110	M35 x 1,5	94	70	47	41	85	45	40	35	49	28	38	71	36	35
S1	G1-50	G2- 50	G2-50B	G6- 50	G6-50B	120/125	M45 x 1,5	116	80	58	63	105	55	50	40	61	35	43	80	46	45
S1	G1-60	G2- 60	G2-60B	G6- 60	G6-60B	130	M58 x 1,5	130	100	70	59	130	65	60	50	75	44	54	100	59	59
S1		G2- 70	G2-70B	G6- 70	G6-70B	140/150	M65 x 1,5	154		82		150	75	70	55	86	49	65	111	66	
S1		G2- 80	G2-80B	G6- 80	G6-80B	160	M80 x 2	176		95		170	80	80	60	102	55	74	120	81	
S1		G2- 90		G6- 90		180	M100 x 2	206		113		210	90	90	65	124	60		125	101	
S1		G2-100		G6-100		200	M110 x 2	230		125		235	105	100	70	138	70		140	111	